



Monocrystalline

Polycrystalline

LP182*182-M-72-MH

Rated Power 530-550W

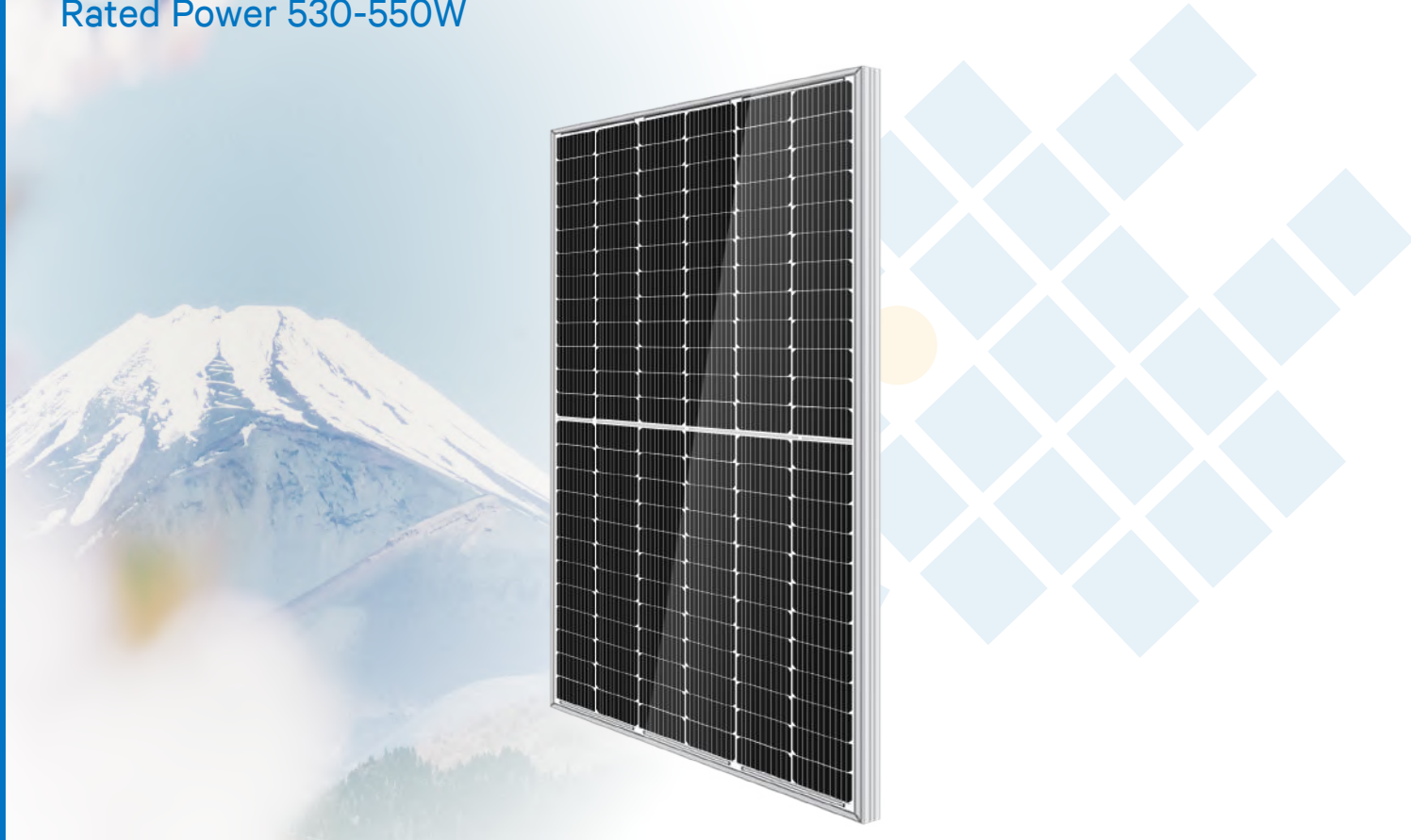

MBB Cell
New circuit design, lower internal current, lower internal resistance loss.



Low Light Features
Higher performance under low light environment.



Higher Output Power
Module adopts 144 pcs of 182*182mm half cells, the maximum power can reach 550W.



PID Protection
Ensure the attenuation probability caused by PID phenomenon is minimized.



Harsh Environmental Adaptability
Strict salt spray and ammonia corrosion test by TUV Nord.



Load Capacity
Mechanical load tests including wind load 2400 Pa and snow load 5400 Pa done by TUV Nord.

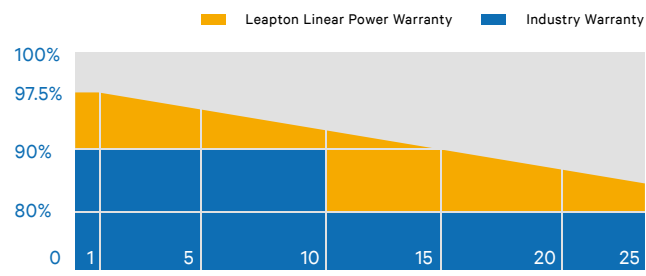

*J-PEC Product



IEC 61215-2: 2016
IEC 61730-2: 2016

MECHANICAL DIAGRAMS

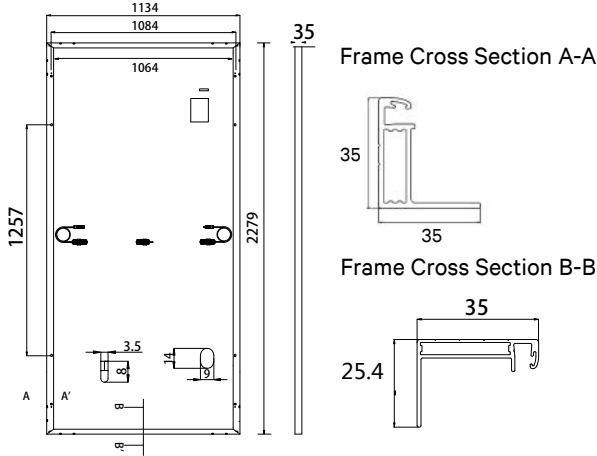

SPECIFICATIONS

Weight	29kg
Dimensions	2279mm*1134mm*35mm
Cell Dimensions	182*182mm
Cell Amount	72*2 pcs
Maximum System Voltage	1500V
Junction Box	IP68
Frame	Aluminum Alloy
Cable	4mm ² , Landscape: N 1400mm/P 1400mm Portrait: N 200mm/P 300mm
Connector	MC4 compatible
Application Level	Class A

ELECTRICAL PARAMETERS AT STC

Power	530W	535W	540W	545W	550W
Open Circuit Voltage	49.00V	49.20V	49.40V	49.60V	49.80V
Short Circuit Current	13.76A	13.81A	13.87A	13.93A	13.99A
Maximum Power Voltage	40.80V	41.00V	41.20V	41.40V	41.60V
Maximum Power Current	13.00A	13.05A	13.11A	13.17A	13.23A
Module Efficiency	20.5%	20.7%	20.9%	21.1%	21.3%

* Under Standard Test Conditions (STC) of irradiance of 1000 W/m², spectrum AM 1.5 and cell temperature of 25°C.

ELECTRICAL PARAMETERS AT NMOT

Power	395W	399W	402W	406W	410W
Open Circuit Voltage	45.90V	46.10V	46.30V	46.40V	46.60V
Short Circuit Current	11.09A	11.13A	11.18A	11.23A	11.28A
Maximum Power Voltage	38.00V	38.20V	38.40V	38.60V	38.80V
Maximum Power Current	10.40A	10.44A	10.49A	10.54A	10.58A
Module Efficiency	15.3%	15.4%	15.6%	15.7%	15.9%

* Under Nominal Module Operating Temperature (NMOT), irradiance of 800 W/m², spectrum AM 1.5, ambient temperature 20°C, wind speed 1 m/s.

TEMPERATURE CHARACTERISTICS

NMOT	41±3°C	Temp Coefficient of ISC	+0.05%/°C
Temp Coefficient of VOC	-0.28%/°C	Temp Coefficient of Pmax	-0.36%/°C

PACKING CONFIGURATION

Modules/Pallet	31 Pieces	Modules/40'Container	620 Pieces
Packing Description	20 Pallets, Total=(31+31)x10=620 Pieces		

CHARACTERISTICS

LP182*182-M-72-MH-530W

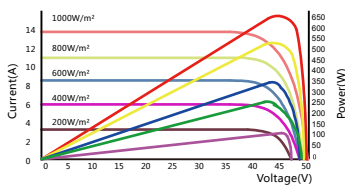

LP182*182-M-72-MH-530W

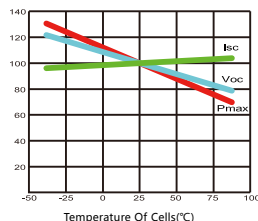

MAXIMUM RATING

Output Tolerance	0~+5W
Operating Temperature	-40°C~+85°C
Wind Load/Snow Load	2400pa/5400pa
Fuse Current	25A

